

PRODUCT INFORMATION PACKET

Model No: 5KCR48TN8062
Catalog No: C194
3,3450,DP,145T,1/60/115/230
Open Drip Proof (ODP)



Regal and Marathon are trademarks of Regal Beloit Corporation or one of its affiliated companies.
©2018 Regal Beloit Corporation, All Rights Reserved. MC017097E





Nameplate Specifications

Output HP	3 Hp	Output KW	2.2 kW
Frequency	60 Hz	Voltage	115/230 V
Current	29.4,14.7 A	Speed	3450 rpm
Service Factor	1.15	Phase	1
Efficiency	78.5 %	Duty	Continuous
Insulation Class	B	KVA Code	J
Frame	145T	Enclosure	Drip Proof
Overload Protector	N/R	Ambient Temperature	40 °C
Drive End Bearing Size	6205	Opp Drive End Bearing Size	6203
UL	Recognized	CSA	Yes
CE	N		

Technical Specifications

Electrical Type	Capacitor Start Capacitor Run(CSCR)	Starting Method	SM
Poles	2	Rotation	Counterclockwise/Clockwise
Mounting	Rigid base	Motor Orientation	Any
Drive End Bearing	BALL	Opp Drive End Bearing	BALL
Frame Material	Rolled Steel	Overall Length	13.13 in
Frame Length	8.43 in	Shaft Diameter	0.880 in
Shaft Extension	2.25 in		
Outline Drawing	52A109637P2	Connection Diagram	52A105381BC

This is an uncontrolled document once printed or downloaded and is subject to change without notice. Date Created: 06/29/2018

52A109637

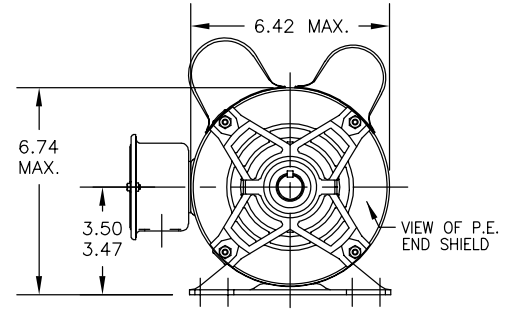
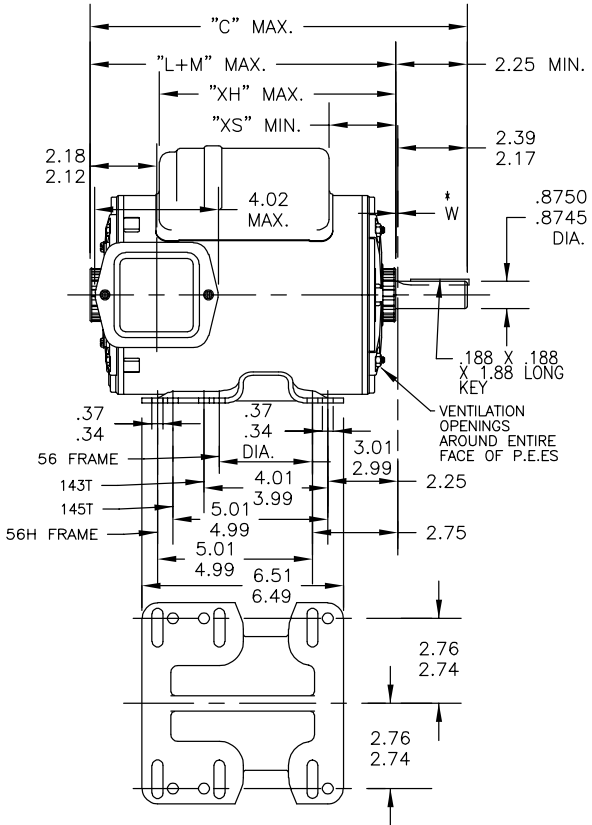
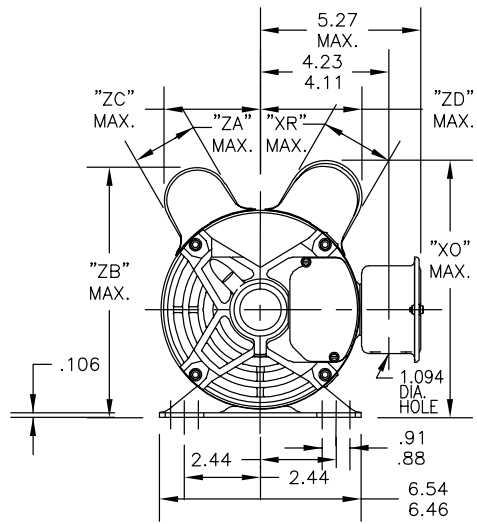

* W IS A VARIABLE CLEARANCE DUE TO VARIATIONS IN PARTS AND ASSEMBLY

ALL DIMENSIONS ARE IN INCHES

2	KCR	48	143T 145T	13.13	10.76	7.76	7.81	1.60	2.01	2.40	8.40	3.38	2.86	8.43
1	KCR	49	143T 145T	14.33	11.96	8.30	8.78	2.72	2.61	2.10	8.16	3.14	3.43	9.63
P	TYPE	RBC SIZE	NEMA FR.	"C"	"L+M"	"XH"	"XO"	"XR"	"XS"	"ZA"	"ZB"	"ZC"	"ZD"	MIN. SHELL

			TOLERANCES UNLESS SPECIFIED				DRAWN M.D.P 06/22/94		
			DEC. INCHES				CHK		
			.X ±0.1				APPD M.D.P 06/22/94		
4	REDRAWN IN DRAFT SIGHT NO CHANGES	GR 10/16/12	PKG .XX	±0.02	TITLE		SCALE 1=1		
3	CHG TO RBC FORMAT PER IS05-1777	SD 03/22/06	.XXX	±0.005	OUTLINE		REF		
2	REV. O.E. E.S. PER TI95-22196.	MDP10/20/95	.XXXX	±0.0005	DP- WELDED BASE		FMF		
NO.	REVISION	BY & DATE	CHK ANG	±1.0	FINISH		PREV		
THIS DRAWING IN DESIGN AND DETAIL IS OUR PROPERTY AND MUST NOT BE USED EXCEPT IN CONNECTION WITH OUR WORK ALL RIGHTS OF DESIGN AND INVENTION ARE RESERVED THIS IS AN ELECTRONICALLY GENERATED DOCUMENT - DO NOT SCALE THIS PRINT				RFP	CAD FILE	52A109637	SIZE	DRAWING NO.	REV.
				DIST			A	52A109637	4

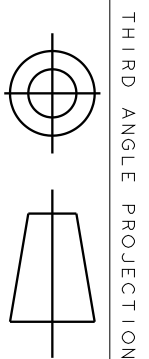

THIRD ANGLE PROJECTION

REV.	DESCRIPTION	REVISIONS
3	UPDATED FORMAT	

CCW/CW ROTATION - DUAL VOL
TYPE KCR

SIZE	DRAWING NO.
	52A105381BC

REV	SHEET
3	1

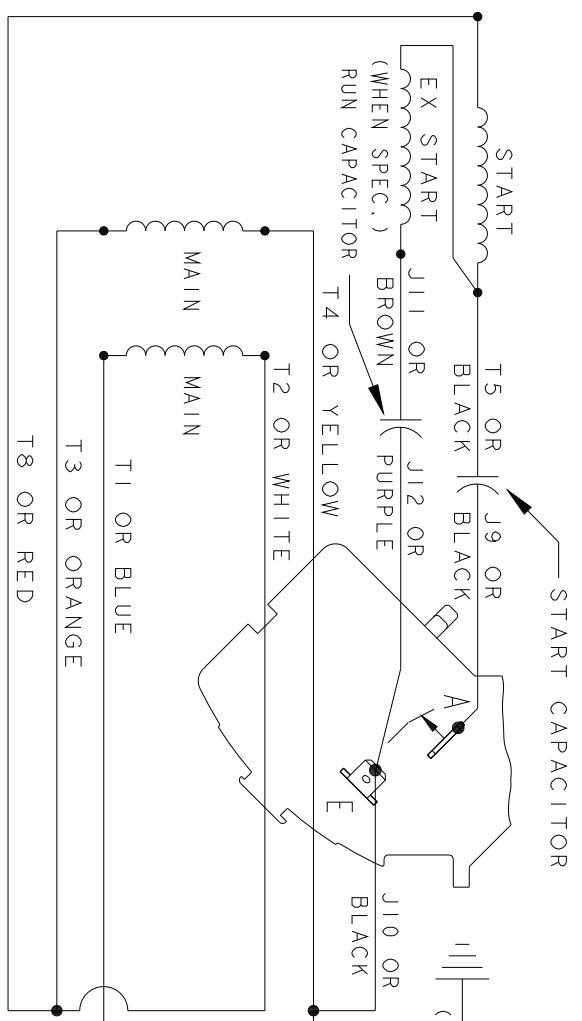
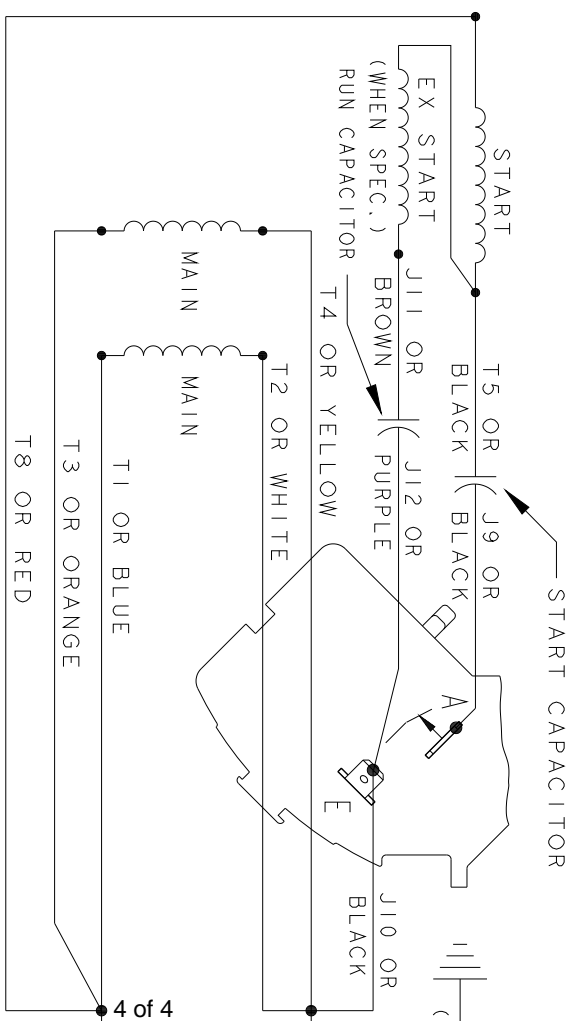

NOTE#1 - TO REVERSE ROTATION, INTERCHANGE T8 RED AN
NOTE#2 - WHEN MORE THAN ONE CAPACITOR IS USED, CONN

SWITCH (H) - 11

REF. DIAG. - 119A93Z24

CONNECTION LABEL

SIGNATURES		DATE	
MODEL	M.D. PAPER	05/09/90	
DETAIL			
CHECKED			
ENGRG			
FOR ADDITIONAL INFO REFER TO:			
APPLIED PRACTICES			
DIMENSIONS ARE IN INCHES			
MATERIAL			

TITLE		SCALE: 1.000	
CONNECTION		REF. No:	
SIZE DRAWING			
A			
FMM:		SK	



REGAL BELT